

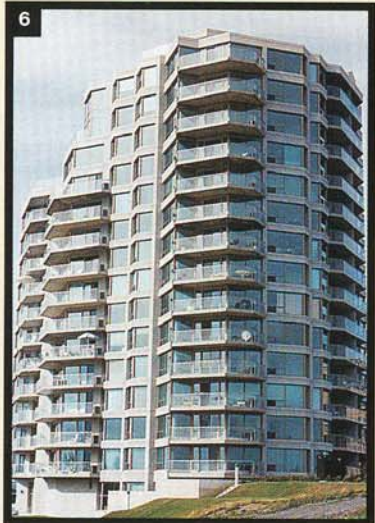

GFRC
INNOVATION
BY DESIGN

*Innovation by Design:
Glass Fiber Reinforced Concrete Cladding*

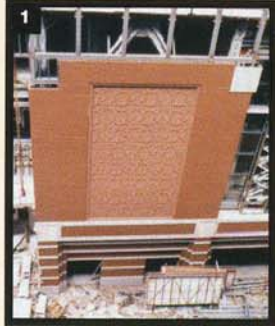



GFRC

WHAT IS GFRC?



Glass Fiber Reinforced Concrete (GFRC)...one of the most innovative construction materials available today — facilitates unprecedented opportunities for design.

GFRC boasts over 20 years of proven performance since alkali-resistant glass fibers were first developed in 1969.

GFRC is a portland cement-based composite with alkali-resistant glass fibers that are randomly dispersed *throughout* the product. The fibers serve a purpose similar to the reinforcing steel in reinforced concrete which is placed primarily in tensile stress areas.

Because the glass fibers add flexural, tensile and impact strengths, the resulting material allows the production of strong — yet lightweight — GFRC architectural cladding panels.

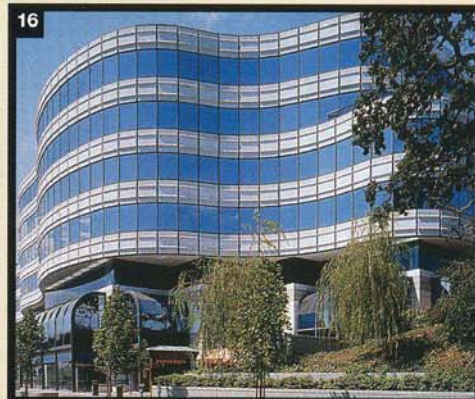

GFRC

APPLICATIONS & ADVANTAGES



GFRC cladding panels are available as wall units, window wall units, spandrels, mullions and column covers. Custom designed in sizes to suit the modular planning of the building, their largest dimensions may be vertical or horizontal.

Versatile GFRC is also suitable for use as fascia panels, soffits, sun screens, mansard roofs and interior feature panels. GFRC cladding panels are capable of accepting and transferring wind and self-weight and their own inertial seismic loads to the building's load resisting system, but are not considered as vertical loadbearing components or as part of the lateral load-resisting system.

Unlike many other exterior wall systems, GFRC panels are normally delivered to the site with steel studs integrated into the panels. This avoids the time and expense of adding the studs later.

It is important in evaluating costs to realize that GFRC panels provide more than the exterior finish. The steel stud frame provides a surface for applying the interior finish, such as drywall, as well as the window frame. It also provides a cavity for installation of insulation, plus electrical, mechanical and telephone conduits. This decreases the floor space needed for these items and eliminates trade overlap problems. And, since insulation is applied between the studs, U-values as low as 0.04 are possible without adding to the wall thickness. The GFRC wall system can also be designed to hang outside the floor slab. As a result, the net rentable or usable floor space can be increased which can appreciably affect the economics of a multi-story project.

The low weight of GFRC panels decreases superimposed loads on the

building's structural framing and foundation, providing potential savings in multi-story construction and in areas with poor supporting soil. Its light weight also makes it ideal for use on low-rise frame buildings where heavier cladding systems would increase the size of framing members required.

Further savings can be achieved by using less expensive fastening hardware due to the panel's lighter weight.

The light weight of GFRC panels allows the contractor to quickly and efficiently erect panels even in hard-to-reach areas with smaller, less expensive cranes.

The reduced construction time also results in faster enclosure of the building, allowing quicker access by other trades. This faster completion time reduces interim financing costs, often resulting in earlier cash flow.

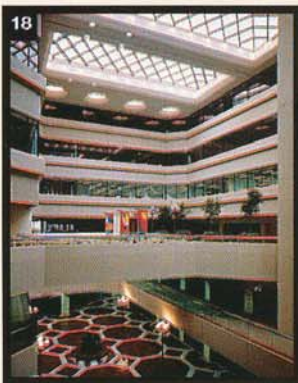

GFRC is ideal for building rehabilitation or renovation projects. Its light weight minimizes the load added to the existing structure. Its design flexibility in color, texture, pattern and surface finish allows it to blend with other construction materials. Exact replicas of original ornamental work from landmark and other historic buildings can be made of GFRC.

And, because GFRC is inorganic and does not contain materials that will burn or produce noxious gases, it does not add to the fire load of a building.

GFRC systems can be designed to provide the various degrees of fire resistance that may be required by building codes, insurance companies and other authorities.



GFRC

COLOR, FORM & TEXTURE

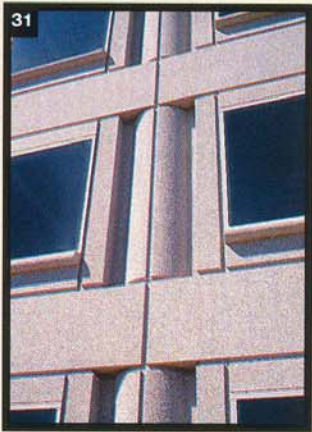

GFRC allows the architect great flexibility in designing the most visible element of a structure — its cladding.

The variety of sculptural shapes made possible through the GFRC manufacturing process enables a wide range of creative architectural design.

The designer can choose from deep reveals to complex rectilinear and curvilinear shapes, such as short radius curves, wide sweeping arcs or 90-degree angles.

The degree of such complex shaping has minimal effect on the cost of the panel due to GFRC's inherent design flexibility. Optimum economy occurs, however, when reuse of forms is maximized with product repetition.

The sculptured shapes that are possible with GFRC window wall panels allows for the design of many types of shading devices for window areas, including vertical and horizontal sunshades. For example, profiled window wall units can form deeply recessed window frames that provide a high degree of sun shading and

minimal solar heat gain without reducing natural light and view.

GFRC panels can be produced in many colors or textures. It is not only compatible with all structural systems, but can also be designed to harmonize with all other materials.

GFRC can be easily produced to match a granite or limestone facing; it can even be made to resemble a metal panel or match ornate terra cotta.

A wide variety of different aggregate colors can be formulated in the face mix. Panels can be produced with a 1/8- to 1/2-inch face mix with decorative aggregates. The aggregate may be exposed by retarders, sand or abrasive blasting; acid etching, or honing and polishing to produce the desired effect. Light, medium or deep exposure of aggregates is possible.

The cement matrix also offers a wide choice of color variations through the use of grey, white or buff-colored portland cements or through the use of color pigments. If deeper colors are required, concrete coatings or stains

can be applied for an even wider variety of color options.

A smooth, off-the-form finish may be the most economical, but color uniformity of grey, buff or pigmented surfaces may be difficult to achieve.

The aesthetic limitations of smooth GFRC can be solved by the shading and depth provided by creating profiled surfaces, such as fluted, sculptured or board finishes; subdividing the panel into smaller surface areas; by using white cement, or by use of applied coatings.

A variety of attractive patterns and surface textures can be achieved by casting the panels against form liners. The fine matrix of GFRC allows production of even delicately detailed surface patterns in low relief at a reasonable cost. A form liner can also make smooth surfaces appear more uniform.

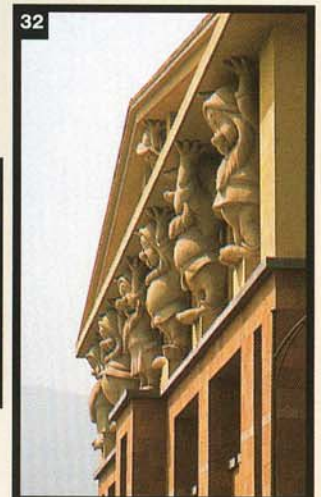



Different shapes and colors of natural stone veneers (such as limestone, marble or granite in narrow strips, small squares and rectangles or regular-sized ashlar pieces) may also be used in creating an almost infinite number of patterns. Clay products, such as veneer-thickness brick, facing tile and architectural terra cotta (ceramic veneer), may also be bonded directly to GFRP, as may mosaics of marble and ceramic.

Maintenance and weathering of the panels will depend largely on its surface finish and local atmospheric pollution. The shape and surface features of the panel will dictate which way water will drain off and to what degree the panel will be self cleaning. It's a distinct design advantage that the architect can choose the shapes, textures and details of GFRP to mitigate the effects of weathering.

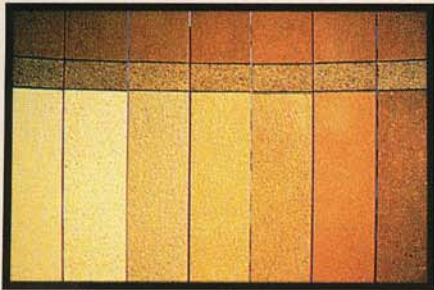
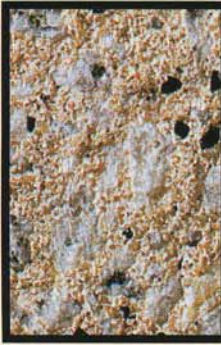
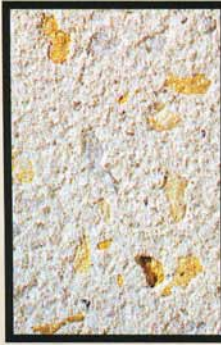
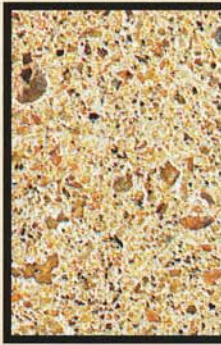
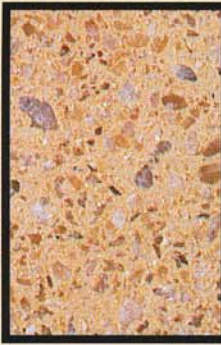

GFRC

REHABILITATION & RENOVATION



34,35

When the owners of this luxury hotel decided to remodel, the architects chose GFRC. The existing building was reinforced to comply with new seismic codes and weight was an issue. GFRC allowed a new lightweight exterior facade to be designed which updated the look of the existing building, originally designed in the 1950s. The design is highly articulated, using many stepped elements and repetitive features. GFRC allowed a very sophisticated facade to be constructed within the constraints of the existing structure and provided an easy transition to the new. Ease of construction with GFRC enabled the owner to meet a tight schedule and keep the hotel open during construction.



36,37,38,39

When the owner decided to remodel this existing six-story cast-in-place building, design/ build proposals were solicited from interested parties. There were many obstacles to overcome while working on an existing, occupied building in the heart of Beverly Hills. To minimize the additional load on the existing building, lightweight GFRC panels were chosen to re clad the building. A tube frame skeleton was installed on the exterior of the cast-in-place building to support the new panels. To overcome the limitation of crane time allowed on the street, the GFRC panels were unloaded from a trailer and handed over to one of two lightweight cranes placed on the roof. This crane in turn handed the panel to the second crane which carried it to its final position. As the panels were lowered to their final position, a guide wire attachment on the tube frame skeleton guided them



into position. Two workers on either side of the panel were lowered down in a manhoist to bolt the panels to the tube frame. The glazing was then attached to the GFRC panel frame and the system was caulked to give it the appearance it has today.

40,41,42

A way to improve the appearance of this relatively modest, but highly visible 400,000 sq. ft. corporate campus building was explored when it was decided to install a new roof. The solution was to incorporate a structural steel roof over the original wood roof; and, for appearance, enhance the classical limestone at the entry by adding



8 ft. high by 25 ft. long GFRC fascia panels to simulate the look of carved limestone.

The lightweight GFRC panels eliminated the need for additional supporting steel which would have been necessary with the use of natural limestone.

43,44,G

This commercial space in the heart of the downtown Chicago retail area was renovated to bring back the richness of the original facade. In addition to matching the texture and finish of the original terra cotta, the spandrels, column covers, and column capitals had to align with the existing terra cotta above. Therefore, the GFRC panel cross-section had to be very thin in several locations.



The glazed finishes on the column covers, the cornice, and the entablature very closely match the existing terra cotta above the third floor which has been cleaned. The large size, strength, and durability of the new cladding panels provided an economical, long-term solution to serious deterioration problems.

45,46,47

The design and coordination of joining retail, hotel, office and apartment spaces in and around a medical center was complicated by the differing requirements of each use and the problems of constructing the new additions on top of existing, occupied space.

The existing hotel was enlarged with two additional floors above providing 80 additional rooms. The ground level retail was expanded out to the sidewalk and along the interior street creating 41,000 sq. ft.



Office space was provided on the second and third levels above the retail space for another 30,000 sq. ft.

The lightweight GFRC panels required less steel framing as part of the building structure reducing construction cost and also allowed the construction of substantially more square footage using existing foundations. The panels were formed to many shapes with an economy of materials while maximizing flexibility of design. The steel stud frame system of the panel provided for a rough framed interior wall that could be insulated, furred out and finished with wallboard.

48,49

Two steel-framed floors were added to the three-story concrete frame auto showroom to convert the building into an office and retail facility. The concrete skin



and new frame was then reclad with 36,000 sq. ft. of lightweight GFRC panels with an exposed aggregate finish as well as granite veneer anchored to the GFRC. This addition provides a handsome and colorful blending with the new glass curtainwall.

50,51,52

A flaring GFRC cornice with inset arched windows was designed to give the freestanding 1950's office building a vertical accent when four floors were added.

Because of its light weight and plasticity, GFRC was used to create the complicated shape of the 40 sections of patterned cornice. Each full-floor panel is about 14 ft. high and projects 8 ft. horizontally. The lightweight GFRC allowed the designer to minimize the structural framing holding the cornice in place.

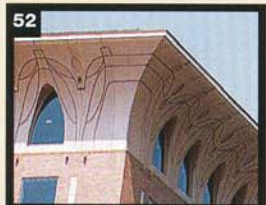
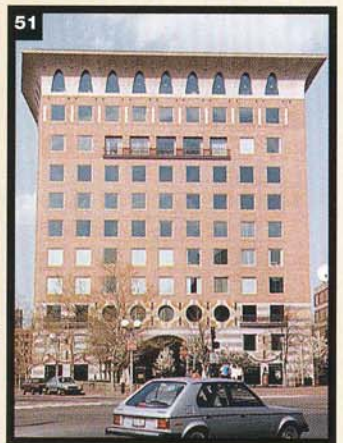

GFRC PRODUCTION

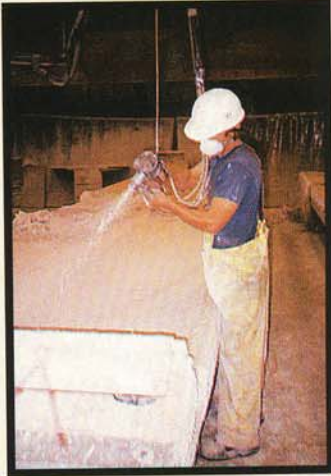

GFRC is manufactured by hand — spraying a cement/sand slurry and glass fibers into forms of the desired shape and size.

The cement/sand slurry is fed via a pump through a slurry spray gun. Attached to the slurry spray gun is an air-powered chopper gun that cuts the continuous glass fiber strands into approximately 1½-inch-long pieces. The chopped fiber strands and the cement/sand slurry are simultaneously propelled onto the form's surface. (A face coat of only the cement/sand slurry may be sprayed on first to provide cover for the glass fibers on the finished face.)

Several layers of slurry and glass fibers are deposited. Each layer is compacted with hand rollers until the required panel thickness, usually ½ inch, is reached. After initial curing, the panel is removed from the form for final curing.

GFRC panels can be produced with or without a face mix of conventional concrete with decorative aggregates. In either case, the cementitious material produces a durable, lightweight wall for the structure. With a face mix, GFRC cladding panels are indistinguishable in exterior appearance from conventional concrete panels.

Unless the panel has a functionally strengthening shape, GFRC properties dictate the use of stiffeners on panels of any appreciable size.

Stiffeners may be prefabricated, plant-attached steel studs or structural tubes, or integral ribs formed on the back of the panel by overspraying hidden rib formers, such as expanded polystyrene strips or adding an up-standing single skin rib on the back of the panel.

Either method stiffens the panel and provides a means for connection to the supporting structure. The steel panel frame is usually the more economical and preferred method for stiffening, except where exposure to the weather or complex shapes dictate the use of integral ribs.

To assure a consistent, uniform manufacturing process, GFRC producers employ strict quality control procedures, such as materials testing, testing during fabrication and testing of the cured composite.

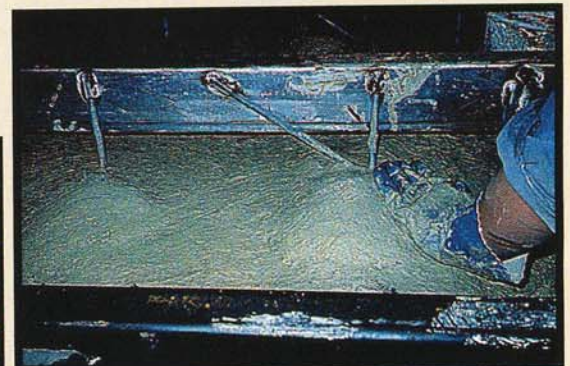
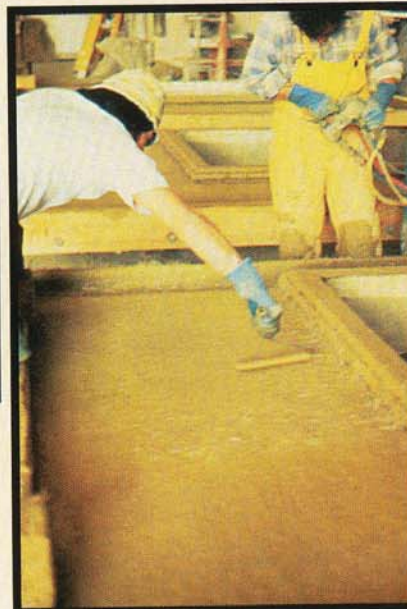

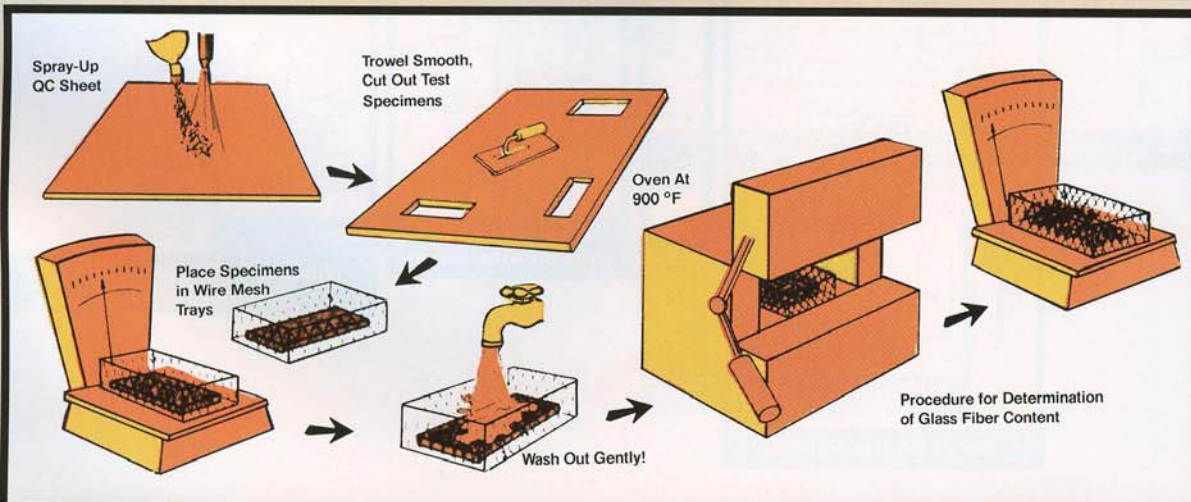
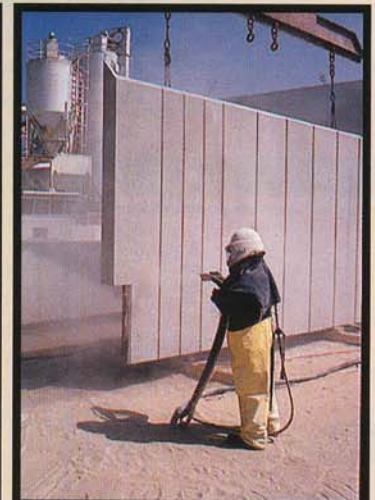
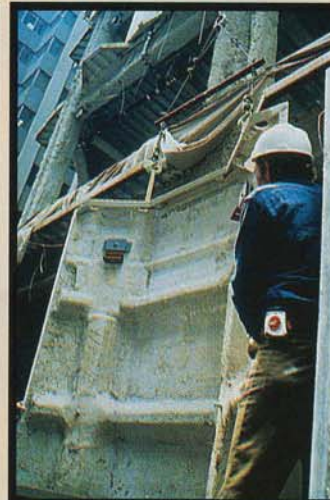
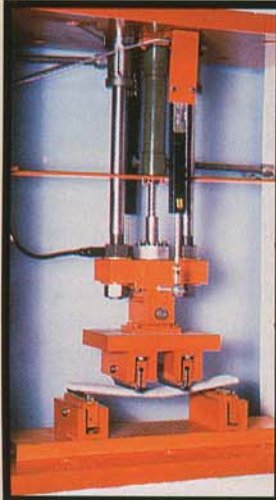

Procedure for Determination of Glass Fiber Content

GFRC

GUIDELINES FOR EFFECTIVE USE

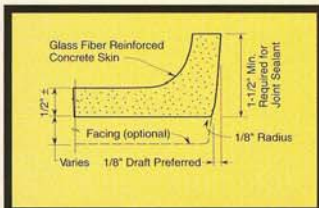

Typical Edge

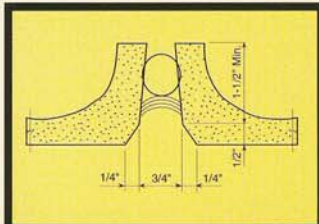

Optional Edge

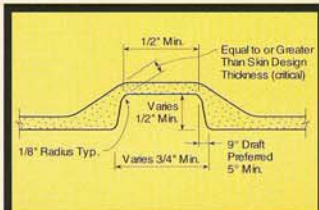

Reveal or False Joint

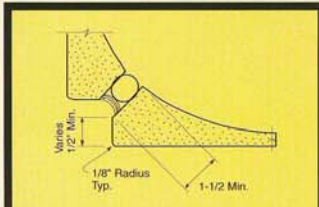

Quirk Miter

One of the greatest benefits of designing with GFRC is that your local GFRC producer is prepared to masterfully execute your concepts, equipped with an intimate knowledge of GFRC technology and the design characteristics of the material. The producer can recommend the most cost-efficient system, assist in the design of fastening devices and in determining erection procedures.

As is the case with other building materials, to achieve a fully satisfactory GFRC panel building requires advance planning and close coordination between the manufacturer, shipper, erector and general contractor. Following are some of the guidelines you and your GFRC panel producer should consider:

- Samples should be developed as a means of translating design concepts into realistic production requirements.

- It is advisable to avoid thin projections whenever possible, use rounded corners and incorporate chamfers at inside corners of the form due to the possibility of fiber bridging.

- With GFRC, you can design deep reveals and curvilinear as well as rectilinear panels.

- In establishing the shape, consider the draft required to strip the unit from the form and to achieve a specific finish. Generally the draft or slope to vertical walls for ease of stripping should be a minimum of 1 inch in 8 inches.

- When the surface of a GFRC panel has two or more different mixes or finishes, a demarcation feature is necessary.

- Carefully calculate the weight savings allowed by lightweight GFRC panels and factor that reduction back into the structural design. Exposed aggregate

facings can increase the weight of a panel, which must be allowed for in the design of the structure.

- During panel erection, priority is given to exterior panel alignment. This may result in the interior stud face not being in a true plane. Panel design usually prevents stud or tube spacing from being coordinated with interior drywall modules. Therefore, it is recommended that, if the studs are to receive interior drywall or similar treatment, drywall be mounted on shimmed transverse furring channels rather than directly to the studs.

- Connection details for each project should be standardized. Repetition of the same connection improves quality control and structural performance. Furthermore, standardization of details facilitates selection and shipment of connection items with fewer delays and added economies.

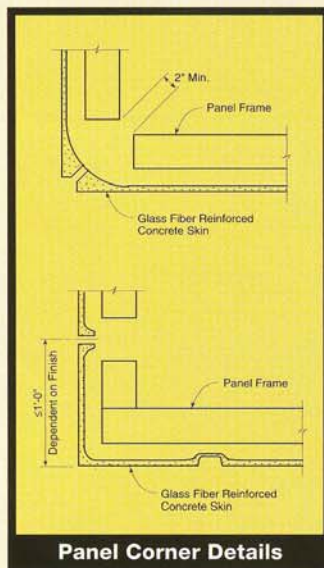

Panel Corner Details

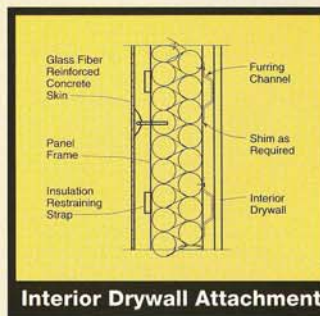

Interior Drywall Attachment

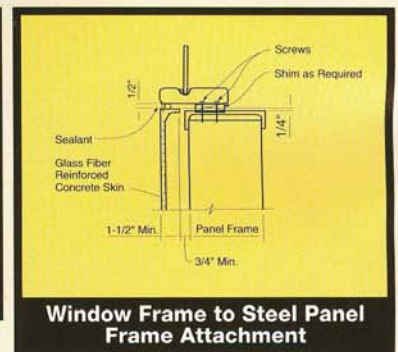

Window Frame to Steel Panel Frame Attachment

■ Windows should be attached directly to the head and sill tracks of the panel frame (or to a separate framing system) with only sealant contact to the GFRC.

■ The design of joints between GFRC panels is an integral part of the total wall design. Requirements for joints should be assessed with respect to both performance and cost. Joint width should not be chosen for reasons of appearance alone, but must relate to panel size and building tolerances, anticipated movement, joint materials and adjacent surfaces. The required width of the joint is determined by the temperature extremes anticipated at the site location, the movement capability of the sealant to be used, the temperature at which the sealant is initially applied, panel size and fabrication tolerance of the GFRC units. Minimum design joint width should be 1/2 inch, 3/4 inch preferred, and minimum panel design return for the joint should be 1 1/2 inches.

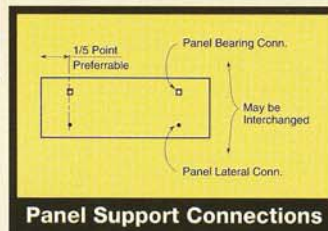
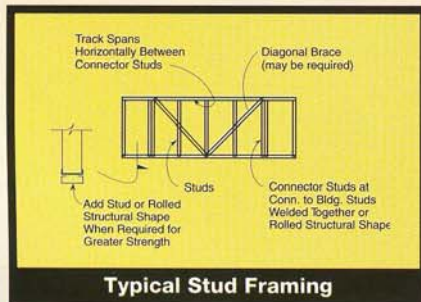
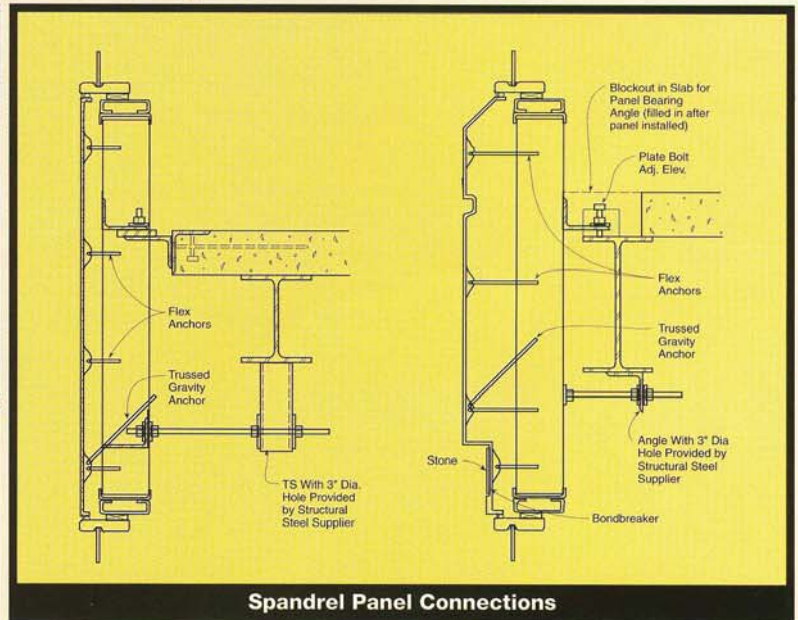
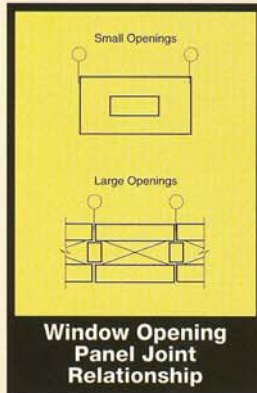
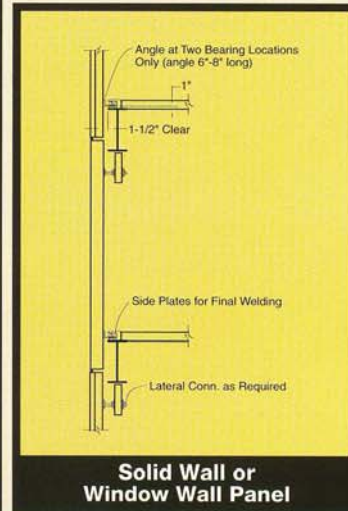
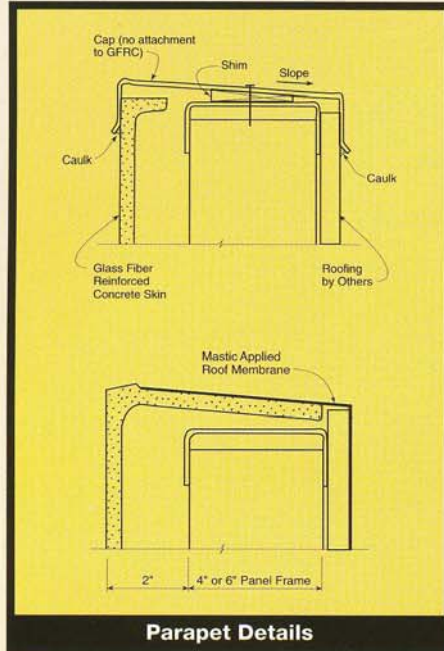

GFRC SUMMARY



Versatility...light weight... money savings...unlimited diversity in color, form and texture. These are the advantages GFRC provides for the designer/architect.

For the owner and tenant, GFRC provides durability, fire resistance, sound attenuation, energy conservation and general superior properties inherent in the material.

Talk to your nearest PCI-member GFRC producer company in the early design stages and throughout the development of the contract documents.

Utilize the producer's extensive knowledge in exploring how to best turn your concepts into practical, functional components on your next project.

Then capitalize on your producer's experience in aiding you to design for optimum quality and maximum economy with minimum costs.

REFERENCES

"Recommended Practice for Glass Fiber Reinforced Concrete Panels," MNL-128, Precast/Prestressed Concrete Institute, Chicago, IL, 1989, 92pp. (Revised edition, 1994)

"Manual for Quality Control for Plants and Production of Glass Fiber Reinforced Concrete Products," MNL-130, Precast/Prestressed Concrete Institute, Chicago, IL, 1991, 184pp.

"Glass Fiber Reinforced Concrete Panels" Evaluation Report No. 4359, ICBO Evaluation Service, Inc., Whittier, CA.





Design and materials technology and applications of Glass Fiber Reinforced Concrete (GFRC) are continually developing. Accordingly, the limitations and design parameters of GFRC should be recognized by the owner, architect, structural engineer and contractor. The PCI *Recommended Practice for Glass Fiber Reinforced Concrete Panels* presents information on planning, design, manufacture and installation to help guide designers and builders, and is available from the Precast/Prestressed Concrete Institute.

FRONT COVER:

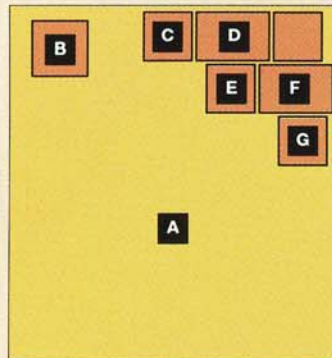

A
Trillium
Woodland Hill, California
Architect: Landau Partnership, Inc.

C
South Bay Center
San Jose, California
Architect: Weaver Architectural Group

D
1700 California Street
San Francisco, California
Architect: Jorge de Quesada Inc., Architects

1,2,3
Cervantes Convention Center
St. Louis, Missouri
Architect: Hellmuth, Obata & Kassabaum, P.C.

B,4
San Francisco Marriott Hotel at Moscone Center
San Francisco, California
Architect: Daniel, Mann, Johnson & Mendenhall

5
Wilshire Doheny Office Building
Beverly Hills, California
Architect: Ellerbe Becket, Inc.

6
Le Classy Condominium
Montreal, Quebec
Architect: Dorel Freedman

7
Armed Services YMCA
Charlestown, Massachusetts
Architect: J.W. French Associates, Inc.

8
720 Market Street
San Francisco, California
Architect: Kinya Tsuruta Associates

9,10
1215 K Street
Sacramento, California
Architect: Hellmuth, Obata & Kassabaum, P.C.

11
Commerce Business Park, Bldg. 118
Commerce, California
Architect: Archaeoderra/Hong/Treiman, Inc.

12
Dorval Pyramid Phase I
Montreal, Quebec
Architect: Dorel Freedman

F,13
Family Life Center
Garden Grove, California
Architect: Gin Wong Associates

14
Salubria Office Park
Oxen Hill, Maryland
Architect: Bower Lewis Thrower

E,15,16,33
1333 North California Boulevard
Walnut Creek, California
Architect: Kaplan/McLaughlin/Diaz

17
Crossroads Plaza Tower
Salt Lake City, Utah
Architect: Timmerman/Stepan Assoc.

18,19
Trans Pacific Centre
Oakland, California
Architect: Wong & Tung International, Inc. and Worley K. Wong • Ronald G. Brocchini & Associates

20
739 Boylston Street
Boston, Massachusetts
Architect: Childs Bertman Tseckares & Casendino, Inc.

21
Nordstrom at the Mall of America
Bloomington, Minnesota
Architect: The Callison Partnership

22,23,24,25
Wilshire Palm Office Building
Beverly Hills, California
Architect: Ellerbe Becket, Inc.

26,27
The Ramada Renaissance Hotel
(now Parc Fifty Five)
San Francisco, California
Architect: Daniel, Mann, Johnson & Mendenhall

28
McDonnell Douglas Center
Huntington Beach, California
Architect: De Revere Partnership

29,30
Loma Linda University Medical Ctr.
South Wing Phase I
Loma Linda, California
Architect: The NBBJ Group

31
Metro Center Office Building "A"
Foster City, California
Architect: Hellmuth, Obata & Kassabaum, P.C.

32
Team Disney Building
Burbank, California
Architect: Michael Graves, Architect

34,35
Miramar Hotel
Santa Monica, California
Architect: Daniel, Mann, Johnson & Mendenhall

36,37,38,39
9301 Wilshire Boulevard
Beverly Hills, California
Architect: R. Nikkhesal

40,41,42
Merck, Sharp & Dohme, Bldg. No. 1
West Point, Pennsylvania
Architect: Francis, Cauffman, Foley, Hoffmann

G,43,44
One North State Street
Chicago, Illinois
Architect: Lobel Schlossman and Hackl

45,46,47
Longwood Galleria
Boston, Massachusetts
Architect: Ayers/Saint/Gross Inc. and LEA Group, Inc.

48,49
Van Ness Plaza
San Francisco, California
Architect: Kaplan/McLaughlin/Diaz

50,51,52
One Bowdoin Square
Boston, Massachusetts
Architect: Graham Gund Architects

53
10380 Wilshire Boulevard
Los Angeles, California
Architect: Shepherd Nelson

54
The St. George Seaside Condominiums and Beach Club
Revere, Massachusetts
Architect: Huygens Di Mella Shaffer and Associates, Inc.

55,56
The Wilshire
Los Angeles, California
Architect: Kaplan/McLaughlin/Diaz

57
Ogden City Center
Ogden, Utah
Architect: Valentiner & Associates

58
Santa Fe Pacific Center
Anaheim, California
Architect: Langdon Wilson Architecture

59
Atlanta Airport Hilton and Conference Center
Atlanta, Georgia
Architect: Rabun Hatch & Associates

60,61,62
Fairmont Hotel
San Francisco, California
Architect: Mirio Gaidano Architects



175 W. Jackson Blvd.
Chicago, IL 60604
(312) 786-0300
FAX (312) 786-0353

Printed in USA

For additional information, contact your local PCI producer, or:



Modern Precast Solutions

Zoho Stone LLC

34318 US Hwy 19 N
Palm Harbor, FL 34684
Office: 727.230.6956
Fax: 727.230.9716
www.ZohoStone.com

